

# LS M100 Frequency Inverter Easy Start Guide



The LS M100 Frequency Inverter range is available to order from [inverterdrive.com](https://www.inverterdrive.com)

This guide is intended to complement the user manual provided by the manufacturer. It is provided as a basic introduction to the product for Inverter Drive Supermarket customers. It should not be used as a replacement for the manual issued by the manufacturer.



**This product is not a safety device. All safety considerations including but not limited to Emergency Stop provision should be assessed separately and are outside the scope of this guide.**

## Contents

Page 1	Contents
Page 2	Power and Motor Connections
Page 3	Motor Connections - Star and Delta
Page 4	Parameters - Overview Parameters to set before use
Page 5	How to set a Parameter value
Page 7	How to Operate the Inverter from the keypad
Page 8	How to connect and configure a Potentiometer for remote speed control
Page 9	How to connect and configure a Run Forward or Run Reverse switch
Page 10	How to connect and configure a Run/Stop switch with Forward/Reverse selection
Page 11	How to configure “3-Wire” control with Run Forward Run Reverse and Stop pushbuttons
Page 12	Brake Resistor Connection (size 2 only)
Page 13	How to Reset the Inverter to Factory Defaults

# Easy Start Guide

LS M100 Frequency Inverter

## 1. Power and Motor Connections



Before commencing, confirm that the Inverter and all cables are completely isolated from the power supply, have been isolated for at least 5 minutes and that the motor is not turning.

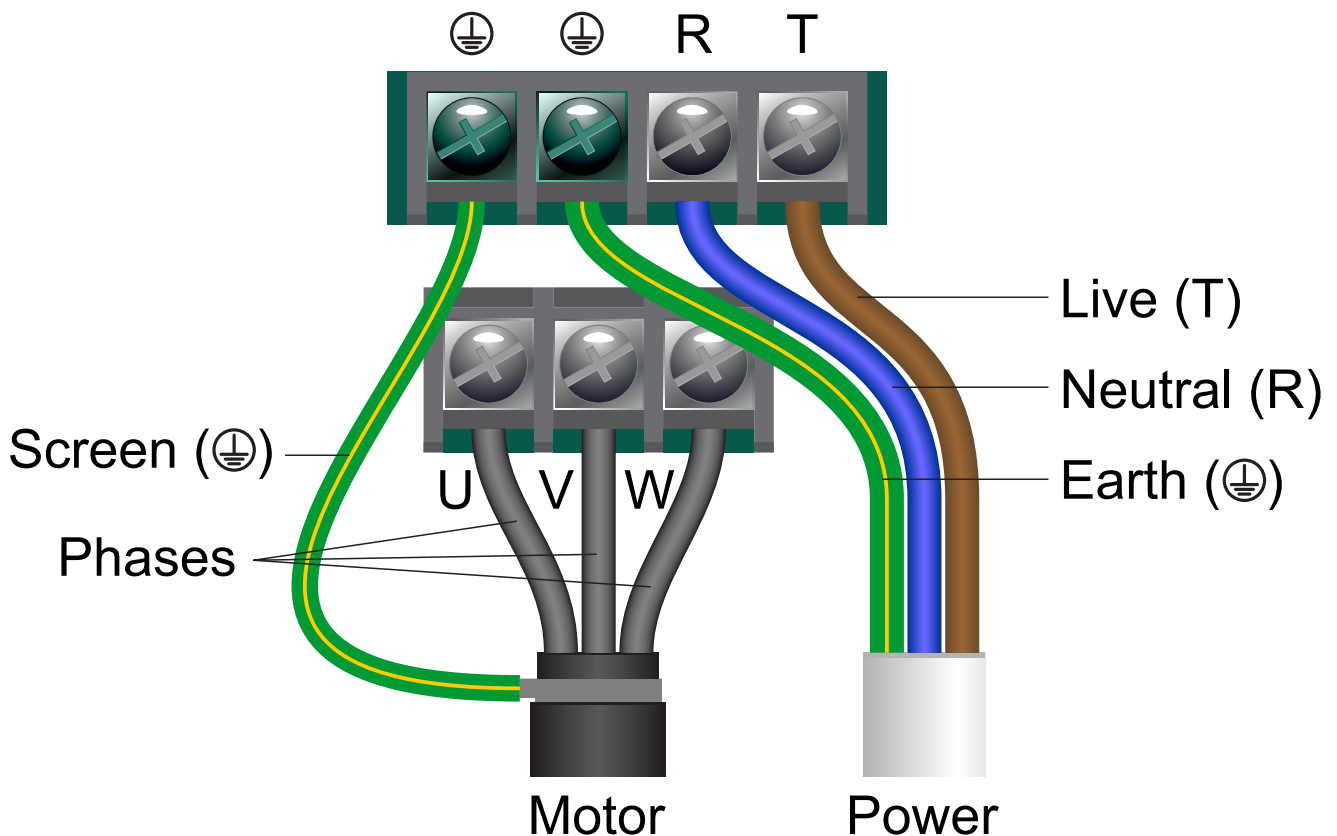

### Notes:

The illustration above is based on the 0.75kW rating (size 2). The terminals for other ratings are similarly labelled.

Connect the motor first as these terminals may not be accessible once power is connected.

The supply must match the Inverter specification and the motor must be separately earthed.

### Important:

The order of the three motor phases determines the initial direction the motor turns.

This can be reversed by swapping any two phases or changing the inverter parameters.

Use screened or armoured cable between the Inverter and Motor and ensure it is grounded as shown.

## 2. Motor Connections - Star and Delta

Dual voltage induction motors typically include terminal boxes with six points. The points can be connected together with links in one of two ways to suit one of the two rated voltages.

The two ways of connecting the links are shown below. These are known as “Star” (the higher voltage) or “Delta” (the lower voltage).

**The selection of Star or Delta is not optional and must match the supply voltage.**

Dual voltage motor nameplates include symbols to represent voltage and full load current in each configuration.

Delta is represented by a triangle and star by a Y (Wye).

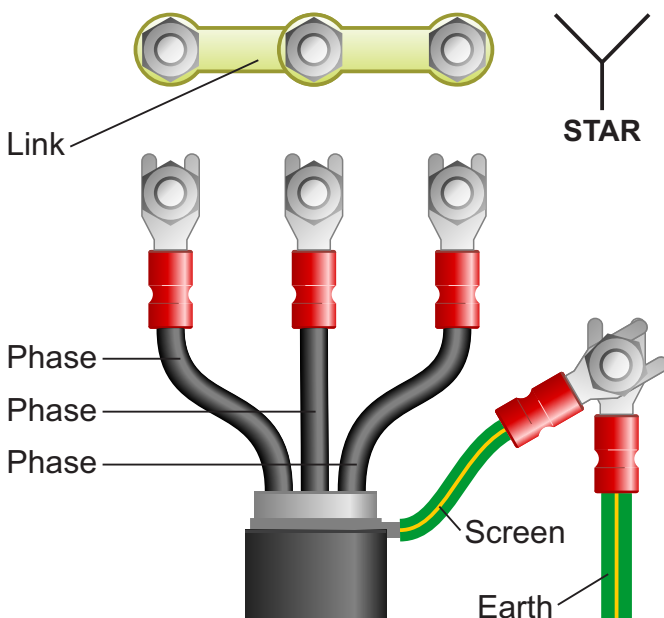

### 2.1 Motor connected in STAR (or Wye):

For safety purposes, Star (shown opposite) is the default configuration for small motors (usually to 3kW) and is sometimes known as “two at one side”.

Only two links are required for Star. Double-up the links if changing from Delta to allow the motor to be changed back in future.

The order of the three phases determines the direction the motor turns.

*Note that the manufacturer recommends that the cable screen is earthed at both ends and the motor and Inverter are earthed separately.*

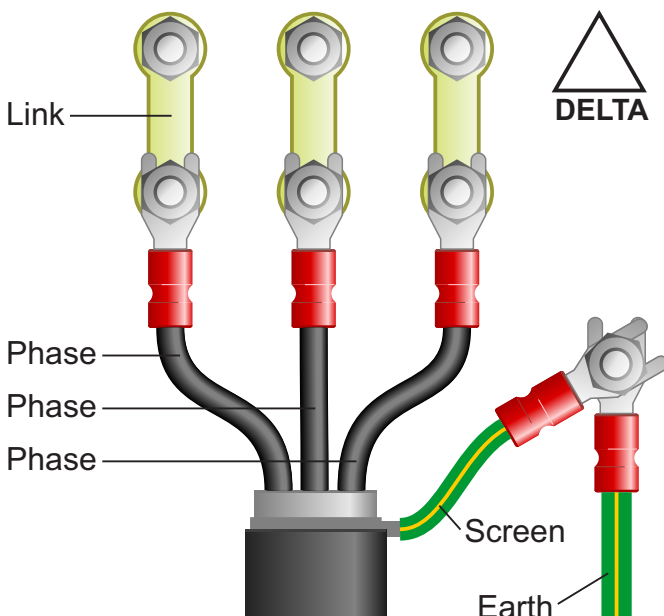

### 2.2 Motor connected in DELTA:

The link configuration is shown in the illustration opposite and is sometimes referred to as “three-a-breast”.

The order of the three phases determines the direction the motor turns.

*Note that the manufacturer recommends that the cable screen is earthed at both ends and the motor and Inverter are earthed separately.*

### 3. Parameters - overview

The Inverter contains a number of settings which can be changed to tailor it for use in a wide range of applications. These settings are known as parameters.

Parameters are typically referred to by code or number (eg. MrC = Motor Rated Current) with a description available in the manual.

The parameters contain critical information essential to the correct operation of the Inverter. Therefore, they should at least be checked by the user before the Inverter is operated for the first time.

The parameters listed in section 4 are intended to provide a starting point to allow for basic operation of the M100 Inverter.

### 4. Parameters to set before use

Set the following parameters to allow the M100 to control a motor with Run, Stop and Speed Control from the keypad.

If any of the parameters have been changed previously, follow the procedure in section 12 to reset the Inverter to Factory Defaults.

**See section 5 to learn how to set a parameter value.**

#### 4.1 Parameters to check and values to set

**Note:** Unlike parameters in all other groups, parameters within the 0.00 (operation) group are not prefixed.

Parameter	Description	How to set
0.00 (or setpoint)	Command Frequency (Hz) (and top of operation group)	Default is 0.00 Hz (zero speed); change to desired speed eg <b>5.00</b> Hz. If an external potentiometer or other speed reference is to be used, ignore this step.
0.00 → ACC	Acceleration time (s)	Default is <b>5</b> seconds; increase or decrease if faster or slower acceleration is required.
0.00 → dEC	Deceleration time (s)	Default is <b>10</b> seconds; increase or decrease if faster or slower deceleration is required.
0.00 → drv	Command source	Default is <b>1</b> for run fwd / run rev via terminals. For alternate control selection is required.
0.00 → Frq	Frequency reference source	Default is <b>0</b> for keypad keys (not dial). Change to 1 for keypad dial.
0.00 → MKW	Motor Rated Power (kW)	Rated Power of the motor. Set to match the motor nameplate eg <b>0.75</b> kW
0.00 → MrC	Motor Rated Current (A)	Rated current of the motor. Set to match the motor nameplate eg <b>2.4</b> A
0.00 → MbF	Motor Rated Frequency (Hz)	Rated motor frequency. Default is 60 Hz; change to suit the motor, normally <b>50</b> Hz in UK.
0.00 → FrM	Maximum frequency (Hz)	Maximum frequency of the Inverter. Set to match MbF (see above) unless an extended speed range is required.
0.00 → IOv	Output voltage setting	Default is <b>0</b> ; suits applications where the motor Volts are the same as the mains supply.
0.00 → Ftb	Forward torque boost (%)	Default is <b>4</b> %; will suit most applications.
0.00 → rtb	Reverse torque boost (%)	Default is <b>4</b> %; will suit most applications.
0.00 → OGr	Open hidden groups	Default is 0. Set to <b>1</b> to extend access to all parameters.
In0 → In39	Frequency corresponding to the V0 input minimum voltage (Hz) (minimum speed)	Default is <b>0</b> Hz at 0V; increase if required. Effects the minimum speed in keypad dial control only. <i>Note: Hidden group; use "Mode" key to select In0 then up/down to select parameter.</i>
In0 → In09	Frequency corresponding to the V1 input minimum voltage (Hz) (minimum speed)	Default is <b>0</b> Hz at 0V; increase if required. Effects the minimum speed using V1 terminal (Analogue Input) only.

### 5. How to set a Parameter value

#### 5.1 Default display

When first powered up the M100 will display the speed setpoint (command frequency).

**Note: this is 0.00 by default but may change once setup has been completed.**



#### 5.2 Select parameter.

Use the up and down arrow keys to select the required parameter. In this example, select OGr (Open Hidden Groups). By default, the M100 only shows the "Operation" group which contains basic parameters - OGr can be used to change this.

Press the "ENT" key to select this parameter and show the value.

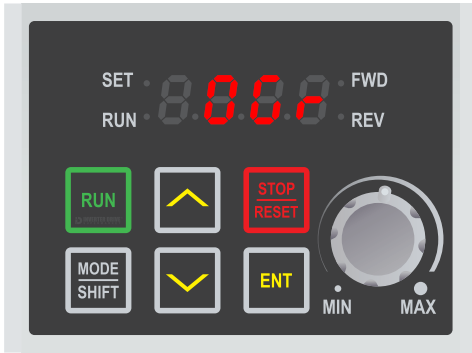

#### 5.3 Change the parameter value and save.

The default value for the OGr parameter is 0 which hides parameter groups. To show all parameter groups (and therefore all parameters) use the up arrow key to change this value to 1.

Press the "ENT" key to save the changes and return to the parameter list. Parameter groups will now be visible unless a factory reset is performed.



#### 5.4 Select parameter group.

Once OGr has been changed to 1, the "MODE" key can be used to cycle through all 10 parameter groups:



All parameter groups have a two character prefix except the "Operation" group, which is displayed as 0.00.



### 5.5 Select the In (Input) parameter group

Press the “Mode” key repeatedly to cycle through parameter groups until the “Input” parameter group is displayed.

The “Input” group can be identified by its “In” prefix.

In0 will be displayed.



### 5.6 Select parameter.

Use the up and down arrow keys to select the required parameter within the group. In this example, select In39 (Frequency corresponding to the V0 input minimum voltage).

Press the “ENT” key to edit this parameter value.

**Note: changing In39 sets the minimum speed in Hz that can be set via the keypad dial.**



### 5.7 Select the digit (optional).

Use the “Shift” key to cycle through each digit. The currently-selected digit will flash to indicate that it can be changed.

This feature can make it easier to set a parameter value but is not required.



### 5.8 Change the parameter value and save.

Use the up arrow key to change the value to 5.00. Then, press the “ENT” key to save the changes.

All digits will flash and “ENT” must be pressed again to confirm the change and return to the parameter list.

To return to 0.00 press the “Mode” key repeatedly.

## 6. How to operate the Inverter from the keypad



### 6.1 Select “local” control mode (keypad run/stop).

As default, the M100 is set to operate from the integrated IO terminals. To operate from the keypad, the “Command Source” needs to be changed.

To do this, change parameter drv from 1 to 0.

**Note:** parameter drv can be found in the “Operation” (0.00) group.



### 6.2 Set the keypad dial as the speed reference.

As default, the M100 is set to operate at a fixed speed set by the 0.00 (Command Frequency) parameter. To operate from the keypad dial instead change parameter Frq (Frequency ref source) from 0 to 2.

**Note:** once Frq is set to 2, the value previously shown as 0.00 will change as the keypad dial is rotated. Use the up/down keys to show this if Frq is still displayed.



### 6.3 Press the green “RUN” key to start the motor.

The RUN key will start the motor. The display will increase as the motor accelerates and the RUN lamp will flash until the desired speed is reached. The time taken for the motor to accelerate to this speed is proportional to parameter ACC. Rotate the keypad dial to change the desired speed.

**Note:** the arrow keys can be used to access the “Operation” parameters; some of these can be used for monitoring such as Cur (motor current) or rPM (rpm).



### 6.4 Press the red “Stop” key to stop the motor.

The STOP key will stop the motor. The time taken (in seconds) to stop the motor is proportional to parameter dEC. The RUN lamp will flash as the motor decelerates. Once the motor is stopped, the display will show the current speed reference set by the keypad dial.

**Note:** the desired speed reference can be set via the keypad dial at any time, even when the M100 is powered down. This can be any value between the min and max specified by parameters In39 and FrM respectively.



## 7. How to connect and configure a Potentiometer for remote speed control

If speed control via the integrated keypad is unsuitable for the application, a remote Potentiometer can be used instead.

This provides the benefit of allowing motor speed to be controlled from a more convenient location such as a cabinet door or on the machine itself.

Any potentiometer rated from 1kOhm to 5kOhm can be used.

The number of turns depends on the application. Both single and multiturn Potentiometers are available from The Inverter Drive Supermarket at [InverterDrive.com](http://InverterDrive.com).

### 7.1 Parameters to check for remote Potentiometer speed control

Parameter	Description	How to set
0.00 → OGr	Open hidden groups	Default is 0. Set to 1 to extend access to all parameters.
0.00 → Frq	Frequency reference source	Default is 0 for keypad keys (not dial). Change to 3 for V1 terminal (remote potentiometer).
0.00 → FrM	Maximum frequency (Hz)	Default is 60 Hz; set to the desired speed when V1 is 10 Volts eg. 50 Hz.
In0 → In09	Frequency corresponding to the V1 input minimum voltage (Hz)	Default is 0 Hz; set to the desired speed when V1 is 0 Volts eg. 5 Hz. <i>Note: Hidden group; use "Mode" key to select In0 then up/down to select parameter.</i>

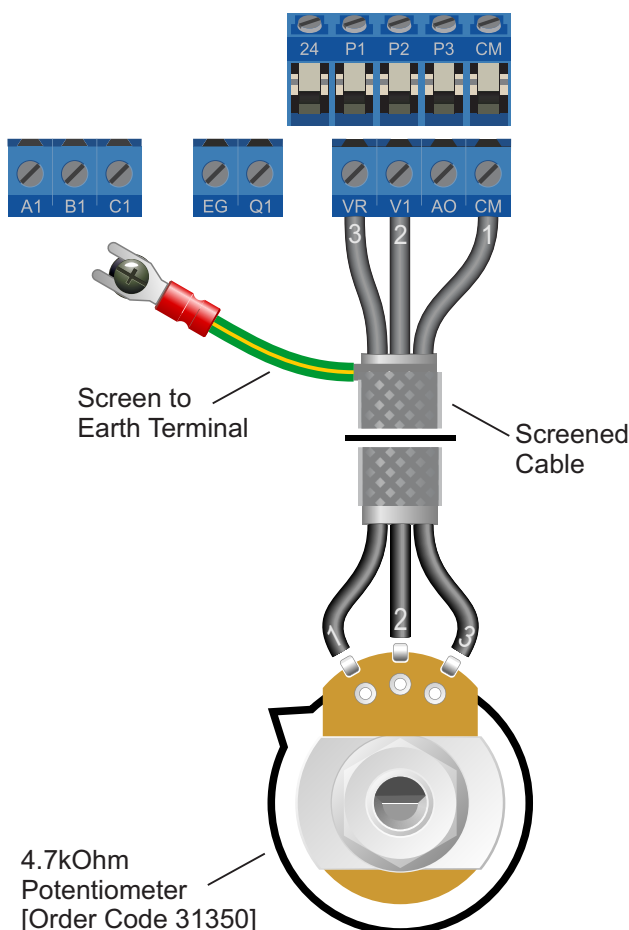

### 7.2 Connecting the Potentiometer

A wiring diagram is shown in the illustration opposite. The most important connection at the Potentiometer end is the centre terminal or "wiper". The wiper will output a variable voltage between 0 and 10 Volts and should be connected to the "V1" terminal on the Inverter. It is this voltage which provides the speed signal with 0V being slowest and 10V fastest.

When Frq = 3, the default output frequency at 0V is the minimum frequency of the Inverter. To change this, edit parameter In09. The default output frequency at 10V is 60Hz. To change this, edit parameter FrM.

If the rotation of the Potentiometer is the opposite to that required (ie. turn anti-clockwise to increase speed instead of clockwise) reverse connections GND and 10V.

Use shielded cable between Potentiometer and Inverter and ensure that the cable screen is connected to the Inverter earth terminal only.

## 8. How to connect and configure a Run Forward or Run Reverse switch

The procedure described in section 6 enables Run/Stop operation via the start and stop buttons on the Inverter keypad.

If this is unsuitable for the application, a remote switch can be used instead.

This section explains how to enable 2-wire control with Run Forward / Stop / Run Reverse commands via a single selector switch.

When set to operate in this way, the Inverter can no longer be operated via the integrated keypad.

### 8.1 Parameters to check for remote Run/Stop

Parameter	Description	How to set
0.00 (or setpoint)	Command Frequency (Hz) (and top of operation group)	Default is 0.00 Hz (zero speed); change to desired speed eg <b>5.00</b> Hz. If an external potentiometer or other speed reference is to be used, ignore this step.
0.00 → OGr	Open hidden groups	Default is 0. Set to 1 to extend access to all parameters.
0.00 → drv	Command source	Default is 1 for FX: Run Fwd and RX: Run Rev; default is required for this example.
In0 → In65	Multi-function terminal P1 setting	Default is 0 for FX: Run Fwd (when drv is 1); default is required for this example. <i>Note: Hidden group; use "Mode" key to select In0 then up/down to select parameter.</i>
In0 → In66	Multi-function terminal P2 setting	Default is 1 for RX: Run Rev (when drv is 1); default is required for this example.

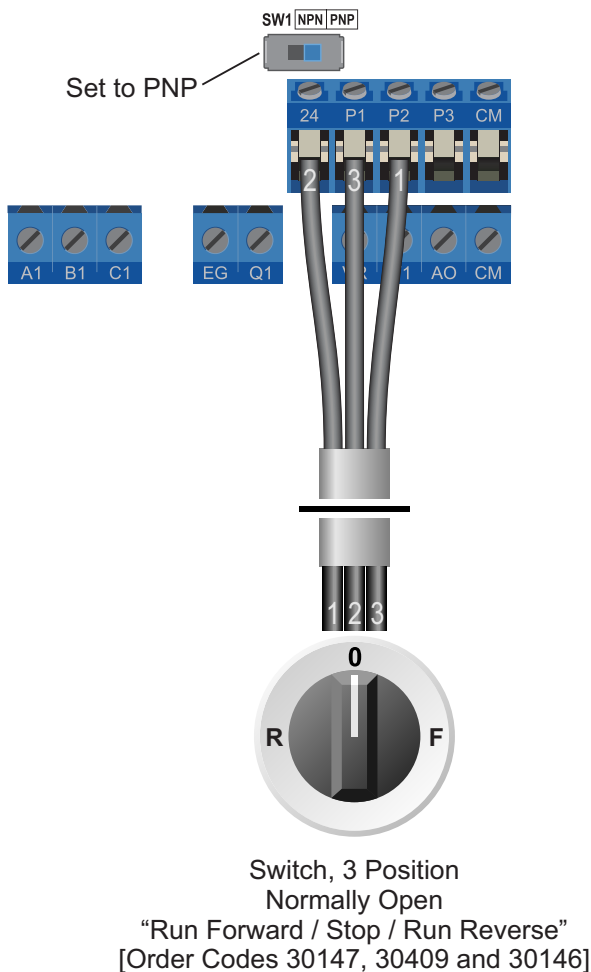

### 8.2 Connecting the Switch

A wiring diagram is shown in the illustration opposite. Ensure that the switch marked "SW1" is set to PNP as shown.

A suitable 3 position NO (Normally Open) switch should be installed between terminals 24, P1 and P2. The centre position should remain open circuit.

When a connection is made between terminals 24 and P1, the motor will run forward. When terminals 24 and P2 are connected, the motor will run in reverse.

If terminals P1 and P2 are connected to 24 at the same time the motor will stop. Parameter deC sets the time to stop in seconds.

If negative logic (NPN) is preferred ensure SW1 is set to NPN and use the CM terminal in place of 24.

**Warning: Failure to select the correct logic (SW1) may result in unexpected operation or no operation.**

# 9. How to connect and configure a Run/Stop switch with Forward/Reverse selection

The procedure described in section 6 enables Run/Stop operation via the start and stop buttons on the Inverter keypad.

If this is unsuitable for the application, remote switches can be used instead.

This section explains how to enable 2-wire control with Run/Stop and Forward/Reverse commands via separate selector switches.

When set to operate in this way, the Inverter can no longer be operated via the integrated keypad.

### 9.1 Parameters to check for remote Run/Stop

Parameter	Description	How to set
0.00 (or setpoint)	Command Frequency (Hz) (and top of operation group)	Default is 0.00 Hz (zero speed); change to desired speed eg <b>5.00</b> Hz. If an external potentiometer or other speed reference is to be used, ignore this step.
0.00 → OGr	Open hidden groups	Default is 0. Set to <b>1</b> to extend access to all parameters.
0.00 → drv	Command source	Default is 1; set to <b>2</b> for FX: Run/Stop and RX: Forward/Reverse.
In0 → In65	Multi-function terminal P1 setting	Default is <b>0</b> for FX: Run/Stop (when drv is 2); default is required for this example. <i>Note: Hidden group; use "Mode" key to select In0 then up/down to select parameter.</i>
In0 → In66	Multi-function terminal P2 setting	Default is <b>1</b> for RX: Forward/Reverse (when drv is 2); default is required for this example.

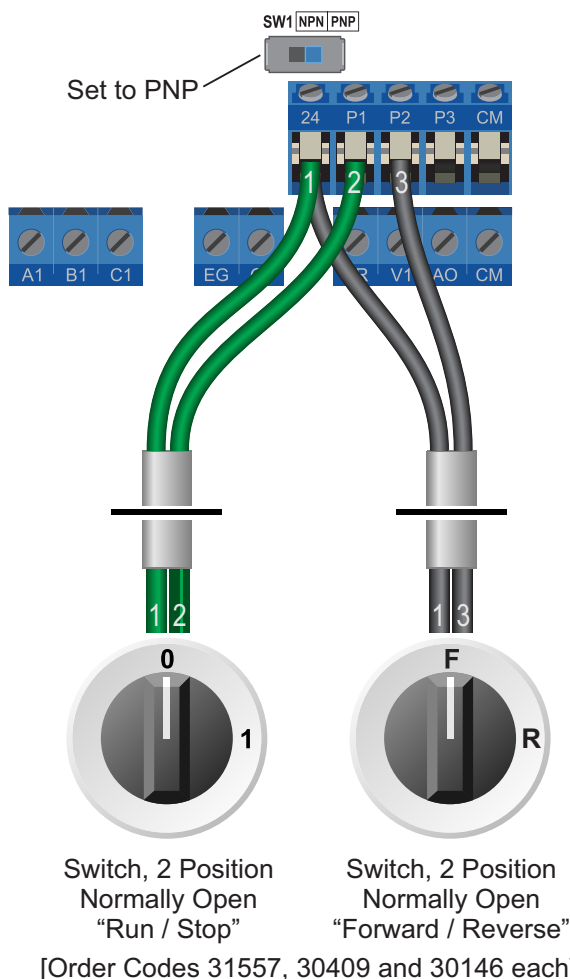

### 9.2 Connecting the Switch

A wiring diagram is shown in the illustration opposite. Ensure that the switch marked "SW1" is set to PNP as shown.

Two suitable 2 position NO (Normally Open) switches should be installed: One between terminals 24 and P1 (Run / Stop) and the other between terminals 24 and P2 (Forward / Reverse).

Note that the Forward/Reverse switch only selects the direction of rotation - it will not start or stop the motor. The direction can be set either before the motor is started or whilst it is running.

If the application only requires the motor to turn in one direction, the Forward/Reverse switch can be omitted.

If negative logic (NPN) is preferred ensure SW1 is set to NPN and use the CM terminal in place of 24.

**Warning: Failure to select the correct logic (SW1) may result in unexpected operation or no operation.**

# 10. How to configure “3-Wire” control with Run Forward Run Reverse and Stop pushbuttons

The procedure described in section 6 enables Run/Stop operation via the start and stop buttons on the Inverter keypad.

If this is unsuitable for the application, remote switches can be used instead.

This section explains how to enable 3-wire control with Run Forward, Run Reverse and Stop commands via separate pushbuttons.

When set to operate in this way, the Inverter can no longer be operated via the integrated keypad.

### 10.1 Parameters to check for remote 3-wire control

Parameter	Description	How to set
0.00 (or setpoint)	Command Frequency (Hz) (and top of operation group)	Default is 0.00 Hz (zero speed); change to desired speed eg <b>5.00</b> Hz. If an external potentiometer or other speed reference is to be used, ignore this step.
0.00 → OGr	Open hidden groups	Default is 0. Set to 1 to extend access to all parameters.
0.00 → drv	Command source	Default is 1 for FX: Run Fwd and RX: Run Rev; default is required for this example.
In0 → In65	Multi-function terminal P1 setting	Default is 0 for FX: Run Fwd (when drv is 1); default is required for this example. <i>Note: Hidden group; use “Mode” key to select In0 then up/down to select parameter.</i>
In0 → In66	Multi-function terminal P2 setting	Default is 1 for RX: Run Rev (when drv is 1); default is required for this example.
In0 → In67	Multi-function terminal P3 setting	Default is 2; change to 17 for 3-Wire control.

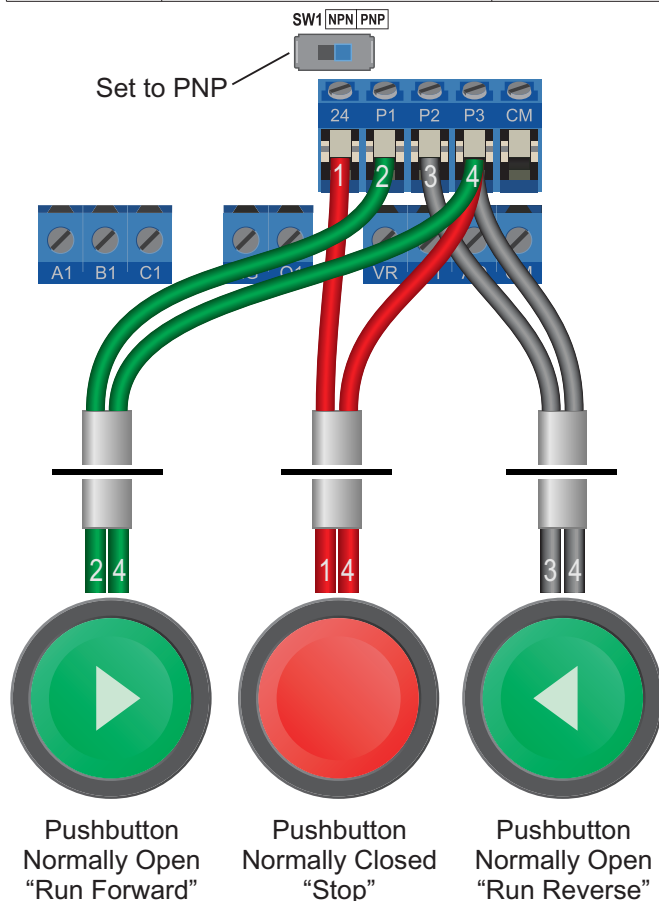

[Order Codes 29992 x 2, 29989, 30409 x 3, 30477, 30146 x 2]

### 10.2 Connecting the Switches

A wiring diagram is shown in the illustration opposite. Ensure that the switch marked “SW1” is set to PNP as shown.

Three suitable pushbuttons should be installed:-  
**Stop:** a normally closed contact between terminals 24 and P3.

**Run Forward:** a normally open contact between terminals P1 and P3.

**Run Reverse:** a normally open contact between terminals P2 and P3.

A momentary connection between P1 and P3 will start the motor (forward). It will continue to run until the connection between 24 and P3 is broken. A momentary connection between P2 and P3 will behave in the same way but the motor will run in reverse.

If the application only requires the motor to turn in one direction, the “Run Reverse” pushbutton can be omitted.

If negative logic (NPN) is preferred ensure SW1 is set to NPN and use the CM terminal in place of 24.

**Warning: Failure to select the correct logic (SW1) may result in unexpected operation or no operation.**

## 11. Brake Resistor Connection (size 2 only)



**Before commencing, confirm that the Inverter and all cables are completely isolated from the power supply, have been isolated for at least 5 minutes and that the motor is not turning.**

High inertia loads can cause overvoltage trips during deceleration and lead to “Ovt” error messages. In many cases, the solution is to increase the deceleration time to compensate.

However, if the application requires it, dynamic braking can be enabled to maintain or reduce deceleration times by absorbing the energy generated by such loads.

A Brake Resistor is first installed to absorb braking energy and dissipate it as heat. The resistor must be correctly sized for both the Inverter and application.

The “brake chopper” within the Inverter detects excessive braking energy and redirects it to the resistor when required.

### 11.1 Parameters to check for Dynamic Braking

Parameter	Description	How to set
0.00 → OGr	Open hidden groups	Default is 0. Set to 1 to extend access to all parameters.
Pr0 → Pr65	DB resistor warning level setting	Default is 1 (warning enabled). Default is recommended. <i>Note: Hidden group; use “Mode” key to select Pr0 then up/down to select parameter.</i>
Pr0 → Pr66	DB resistor warning level (%)	Default is 10 %. Will suit many applications but can be increased to suit specific applications if required.

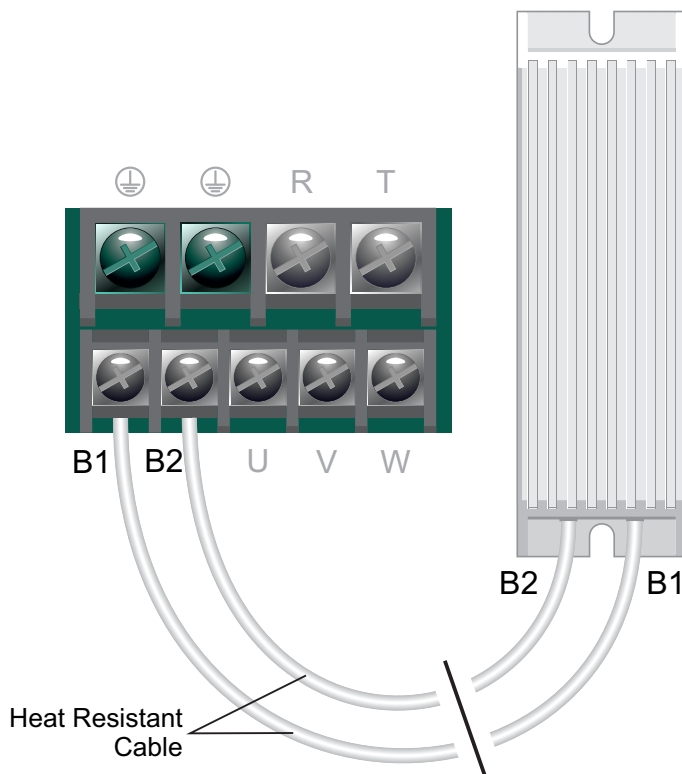

### 11.2 Connecting the Resistor

A wiring diagram is shown in the illustration opposite. Connect the brake resistor to the B1 and B2 terminals on the Inverter. The order of the connections is unimportant.

The braking resistor may get hot during operation. Ensure that it is suitably-mounted so any heat generated will not affect other equipment. Some resistors may include a thermal relay for additional protection.

It is essential that a resistor of the correct rating is used. Consult the Inverter product listing at [InverterDrive.com](http://InverterDrive.com) or manual issued by the manufacturer for details.

## 12. How to reset the Inverter to Factory Defaults

### 12.1 Show hidden parameter groups

Access to hidden parameter groups is required to perform a factory reset. If step 12.2 (below) does not show CF0 then hidden parameter groups must be enabled. To do this:-

From 0.00, use the up and down arrow keys to select OGr then press the “ENT” key to edit its value.

Use the up key to change the value to 1 then press “ENT” to save the changes and “ENT” again to confirm.



### 12.2 Select the “Configuration” parameter group

Once OGr is set to 1, press the “MODE” key repeatedly until the “Configuration” group is shown.

Cf0 will be displayed.



### 12.3 Select parameter CF93

Use the up and down arrow keys to select parameter CF93. Once selected, press the “ENT” key to edit the parameter value.

**Note:** from CF0 it is quicker to use the down arrow key to reach CF93.



### 12.4 Change the parameter value to 1 and save

Use the up key to change the value to 1 then press “ENT” to save the changes and “ENT” again to confirm.

Once the reset is complete, the display will return to the parameter list.

To return to 0.00 press the “Mode” key.

