

# Frequency Converter

## ABZ (HTL / TTL) Encoder Card

Product Insert

R912004809

Edition 01

### 1 Start

ABZ (HTL / TTL) encoder card is one standard extension card for Rexroth frequency converter series of EFC 5610. This ABZ (HTL / TTL) encoder card has to be used with extension card module together.

### 2 Technical Data

Encoder power supply	5 V ± 5 % (200 mA), 12 V ± 5 % (150 mA)
Maximum input pulse frequency	300 kHz
Pulse input voltage	5...24 V
Connector type	Quick connectors
Pulse output	1:1 push-pull output

### 3 Extension Card Mounting

#### ⚠ CAUTION

#### Risk of device damage!

Do not mount the extension card when frequency converter is powered on, otherwise it will cause damage to the extension card.

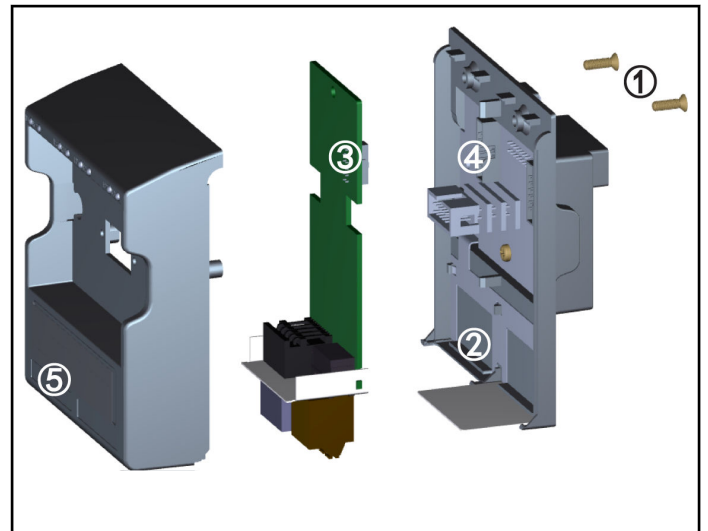

1. Remove 2-M3 screws ① on back of the extension card module.
2. Remove the front cover of the extension card module.
3. Insert one extension card into the card slot with the metal plate beside the extension card terminals placed in ②.
4. Push the extension card to achieve a stable connection of connector ③ (on the back side of the extension card) with connector ④ (on the extension card module).
5. Mount the front cover of the extension card module.
6. Tighten 2-M3 screws ① of the extension card module.
7. Attach an appropriate terminal label on the label indentation ⑤ located at the lower section of the front cover.

### 4 Terminals Mapping

A+	A-	B+	B-	Z+	OA	OB	OZ
PE	E5V	ECOM	E12V	Z-	GND	IN24V	PE

## 5 Terminals Description

Interface	Terminal	Signal function	Description	Signal requirement
Encoder interface	E5V	Encoder power supply 5V	ECOM is reference	Max. output current: 200 mA
	E12V	Encoder power supply 12V		Max. output current: 150 mA
	ECOM	Shared connection of encoder power supply	Isolated from GND	-
	A+	Encoder output signal A+	ECOM is reference	Input voltage range: 5...24 V Max. input pulse frequency: 300 kHz
	A-	Encoder output signal A-		
	B+	Encoder output signal B+		
	B-	Encoder output signal B-		
	Z+	Encoder output signal Z+		
	Z-	Encoder output signal Z-		
PE	Shielding connection	Connected with grounding terminals on heatsink internally	-	
Pulse output interface	OA	Pulse output A	GND is reference (External 24V power supply has to be supplied to terminal IN24V)	Output pulse voltage: 24 V Max. output current: 50 mA
	OB	Pulse output B		
	OZ	Pulse output Z		
	IN24V	External power supply	External 24V ( $\pm 5\%$ ) power supply (not from the frequency converter) input to OA, OB and OZ	-
	GND	Shared connection of pulse output	Isolated from ECOM	-
	PE	Shielding connection	Connected with grounding terminals on heatsink internally	-

## 6 Wiring

### 6.1 Differential Pulse Input Wiring

Encoder power supply		Reference
Source option	Voltage	
Internal	5 V	Wiring 1
	12 V	Wiring 2
External	5...24 V	Wiring 3



1. Please make sure that the power supply has been switched off before wiring.
2. Please check the required voltage of encoder before power on, higher voltage than required will damage the encoder.
3. Using shielded twisted-pair cable as encoder signal cable.
4. Twisted-pair strictly in accordance with the differential pairs on the wiring.
5. Encoder cable shield should be connected to the PE terminal of encoder card.
6. Encoder cable and motor power cable have to be routed separately from each other.

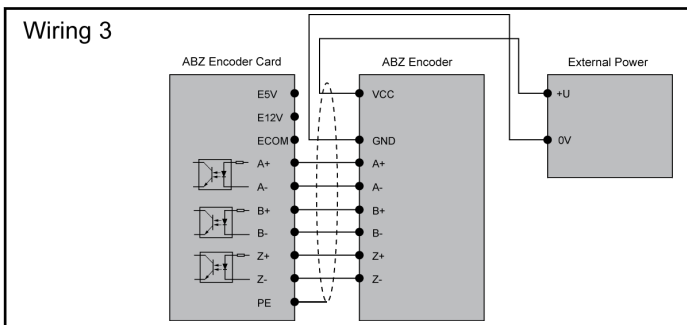
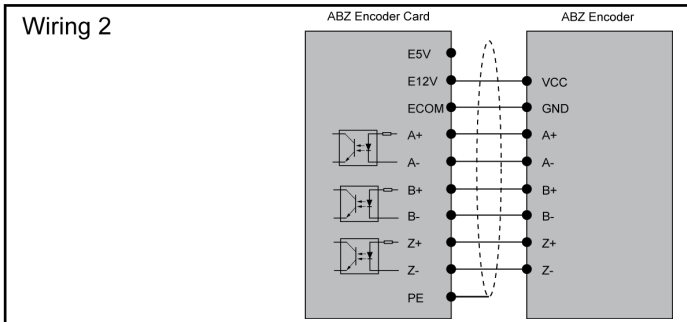
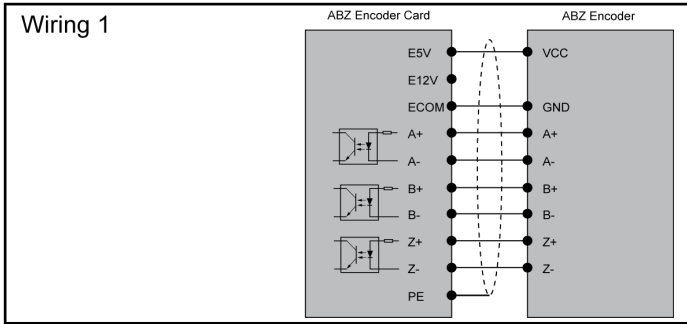

1. Please make sure that the power supply has been switched off before wiring.
2. Please check the required voltage of encoder before power on, higher voltage than required will damage the encoder.
3. Using shielded twisted-pair cable as encoder signal cable.
4. Each input channel (A, B, Z) should use a separated twisted-pair cable. The unused wires should be connected to ECOM.
5. Encoder cable shield should be connected to the PE terminal of encoder card.
6. Encoder cable and motor power cable have to be routed separately from each other.
7. Due to the electrical characteristics of the collector, the rising edge of the signal changes slowly. Signal transmission distance of this kind of encoder is usually less than 50m. For applications where the cable length is greater than 50m, it is recommended to use the differential output encoder, rather than the collector output encoder.

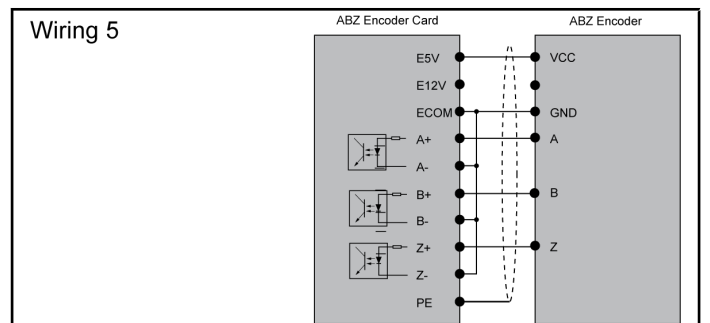
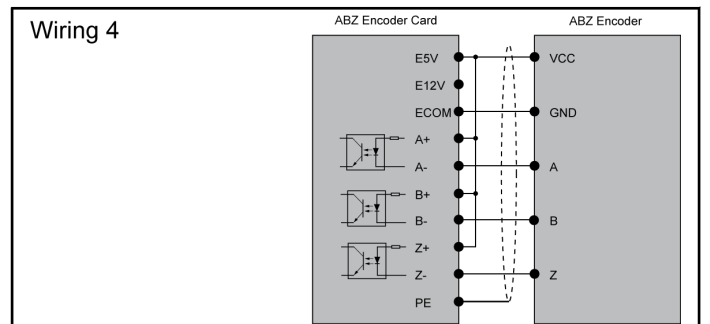

6.2 OC Pulse Input Wiring

Encoder power supply		Interface	Reference
Source option	Voltage		
Internal	5 V	NPN OC	Wiring 4
	5 V	PNP OC	Wiring 5
	12 V	NPN OC	Wiring 6
	12 V	PNP OC	Wiring 7
External	5...24 V	NPN OC	Wiring 8
	5...24 V	PNP OC	Wiring 9

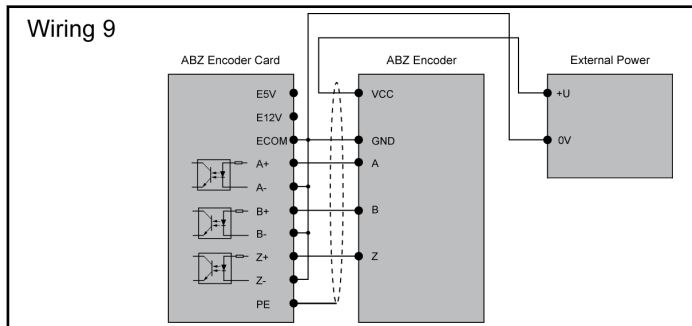
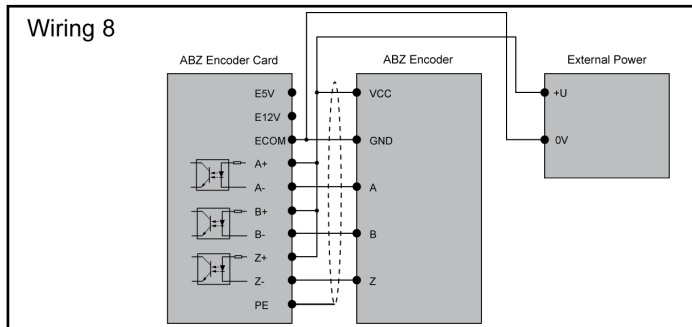
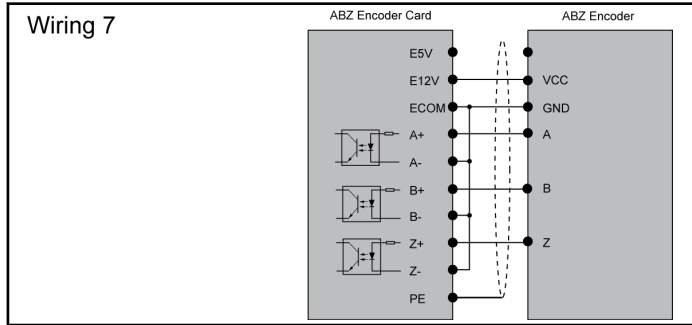
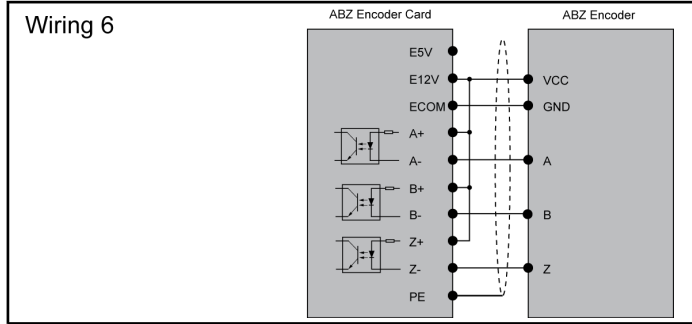

6.3 Push-pull Pulse Output Wiring

Encoder power supply		Output	Reference
Source option	Voltage		
External	24 V	Pull up	Wiring 10
External	24 V	Pull down	Wiring 11



1. Please make sure that the power supply has been switched off before wiring.
2. Please check input pulse voltage of PLC before power on.
3. Using shielded twisted-pair cable as output signal cable.
4. Signal cable shield should be connected to the PE terminal of encoder card.

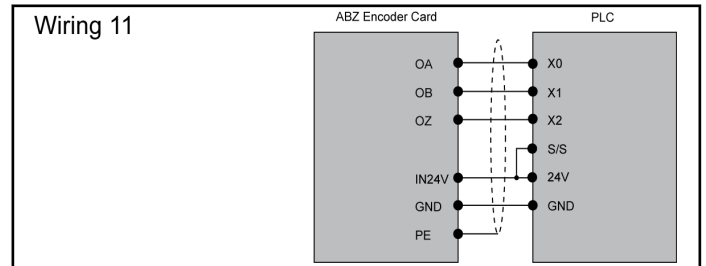
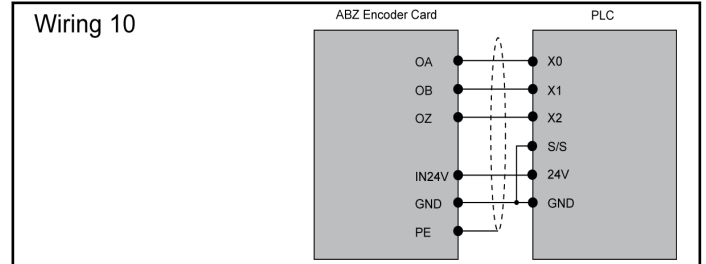

7 Parameter

Code	Name	Setting range	Min.	Default	Attri.
H7.01	Encoder direction	0: Forward 1: Reverse	1	0	◆

Parameter H7.01 is used to change the phase sequence, if the encoder phases are reversely connected. The value of parameter H7.01 will automatically updated after rotation auto tuning if the parameter value of H7.20 is correctly setting before rotation auto tuning.

Code	Name	Setting range	Min.	Default	Attri.
H7.05	Encoder wiring break detection level	0.0 (No protection) 0.1...1,000.0 rpm	0.1 rpm	0.0 rpm	◆
H7.06	Encoder wiring break detection time	0.1...10.0 s	0.1 s	1.0 s	◆

If measured speed is smaller than encoder wiring break detection level [H7.05] and the duration is more than encoder wiring break detection time [H7.06], wiring break error "ElbE" is detected.

This function can be disabled by setting [H7.05] = 0.0.

Code	Name	Setting range	Min.	Default	Attri.
H7.07	Encoder phase order error detection time	0.0 (No protection) 0.1...100.0 s	0.1 s	1.0 s	◆

If measured speed direction is different from running direction and the duration is more than encoder phase order error detection time [H7.07], phase order error "EPOE" is detected.

This function can be disabled by setting [H7.07] = 0.0.

Code	Name	Setting range	Min.	Default	Attri.
H7.20	Pulses per revolution of encoder	1...20,000	1	1,024	◆

Parameter H7.20 is used to set the number of pulses per revolution of the ABZ encoder.

Please correctly set this parameter under vector control with encoder before running.

### 10 Diagnosis

Error code	Display	Description	Possible reason	Solution
70	ElbE	Encoder input broken wire error	1. Encoder connection problem 2. Encoder error	1. Check encoder connection cable 2. Replace encoder
71	EPOE	Encoder phase order error	1. Wrong wiring between encoder and encoder card 2. Improper parameter setting of encoder	1. Check wiring 2. Set parameters related to encoder properly

### 8 Cable Length

Cable length (m)	Cable cross	
	AWG	mm <sup>2</sup>
10	≤ 24	≥ 0.205
20		
30		
40		
50		
60	≤ 23	≥ 0.258
70		
80	≤ 22	≥ 0.326
90		
100		

### 9 Type Code

Typecode	Description
FEAE04.1-EN1-NNNN	EFC 5610 ABZ (HTL / TTL) encoder card
FEAE02.1-EA-NNNN	EFC 5610 extension card module

